

Standard Configuration

Engine

- H, S, L and B modes control
- 24V/5.0kW starter motor
- 50A alternator
- Air prefilter
- Dry-type dual-element air filter
- Cylinder-type engine oil filter
- Cylinder-type fuel oil filter
- Engine oil cooler
- Radiator with protective screen
- Auxiliary radiator water tank
- Fan deflector
- Isolated mounted engine
- Automatic idling system
- Acceleration System

Hydraulic system

- Operating mode selector switch
- Control valve with main overflow valve
- Pipeline of All-function Breaking Hammer
- Oil suction filter
- Oil return filter
- Pilot filter

Upper slewing platform

- Fuel oil level floater
- Hydraulic oil level gauge
- Toolbox
- Slewing parking brake
- Rearview mirror (left/right)
- Anti-collision beam of platform

Cab

- Sound-proof steel-structure cab
- Reinforced light-color glass window
- 6 silicone oil rubber damper supports
- Openable top/front wall upper window and left side window
- Emergency exit on rear window
- Wiper with washer
- Adjustable tilting seat with adjustable armrest
- AM-FM radio with digital clock
- Foot rest and floor mat
- Loudspeaker and rearview mirror
- Seatbelt and fire extinguisher
- Cup holder and compartment lamp
- Ash tray and escape hammer
- Storage box and sundries bag
- Pilot control cut-off lever
- Fully-automatic A/C
- Protective mat

Front-end working device

- Flange pin
 - Tungsten carbide anti-wear coating
 - Welded connecting rod
 - Central lubrication system
 - All bucket pins are equipped with dustproof seal ring
 - 4.6m reinforced all-welded box-type boom
 - 2.5m reinforced all-welded box-type bucket rod
 - Anti-collision guard plate
- ### Monitoring system instruments
- Hour meter and fuel tank oil level gauge
 - Engine coolant temperature
 - Engine oil pressure gauge

Traveling body of undercarriage

- Traveling parking brake
- Traveling motor guard plate
- H-shaped track guide mechanism
- Hydraulic tensioning device of track
- Bolted driving wheel
- Carrier roller and thrust wheel
- Reinforced chain track with pin shaft seal
- 500mm/1'8" three-rib crawler plate
- Reinforced side pedal
- Bottom cover plate

Alarm system

- Insufficient engine oil pressure
- Engine coolant temperature too high
- Insufficient fuel volume
- Blockage of air filter
- Throttle rotary knob failure

Air conditioning system

- Dual-purpose air conditioner
- A/C control panel
- Fresh air inlet system (fresh air exchanging function)

Others

- Standard battery
- Lockable engine hood
- Lockable fuel filler cap
- Traveling direction sign on traveling frame



- Rated power
84kW/2200rpm
- Overall weight
14100kg
- Bucket capacity
0.22-0.7(0.65)m³

SY155H

Hydraulic excavator

BRAND NEW **C10**
QUALITY CHANGES THE WORLD
Wonderful Sany Lead by Innovation



SANY Heavy Machinery Co., Ltd.

SANY Industrial Park, Dongcheng Avenue, Kunshan Economic & Technological Development Zone, Jiangsu Province

○ Post code: 215300 ○ After-sales service hotline:
4008282318

○ Consulting & complaint hotline:
4008879318

○ www.sanygroup.com.cn

Note

This is a sample and is only for reference. All configurations shall be subject to the contract or material object, and may be changed without further notice. All rights reserved! No contents in the sample shall be duplicated or copied for any purposes without written approval of SANY Heavy Machinery.

© Printed in China
No.: ZJSYX0604CH (March 2016)

SY155H

Strong Power Model of heavy- load machines

SY155H hydraulic excavator



SELLING POINTS

As a machine designed by SANY Heavy Machinery for heavy-load work in "mine", the SY155H hydraulic excavator (hereinafter referred to as "SY155H") has been ranking the first in terms of sales volume among all the machines at the same tonnage since its launch in the market.

Featured by "high reliability, superior performance, high safety and environmental protection, comfort and convenience", the Brand New SY155H Hydraulic Excavator supports multiple special configurations to satisfy the requirements of different countries and customers.



High reliability



Excellent performance



Safe & environmental-friendly



Comfortable and convenient

HIGH RELIABILITY

o High reliability in industry

Reliability

- With improvements such as higher reinforcement of structural parts and lower fault rate, SY155H represents the highest reliability in the entire industry.
- Fitted with the work device dedicated for mine, rotary platform with anti-collision beam and heavy and extended chassis, SY155H becomes a typical machine for "mine".



o Best core configuration

Core configuration

- The specific **Isuzu engine for SANY** can keep the Machine reliable even under the most severe working condition.
- The high reliability of hydraulic system is guaranteed by using complete set of **Kawasaki hydraulic system** and internationally famous hydraulic elements.
- The newly designed **reinforced structural parts** can ensure a longer service life.



SANY

Engine

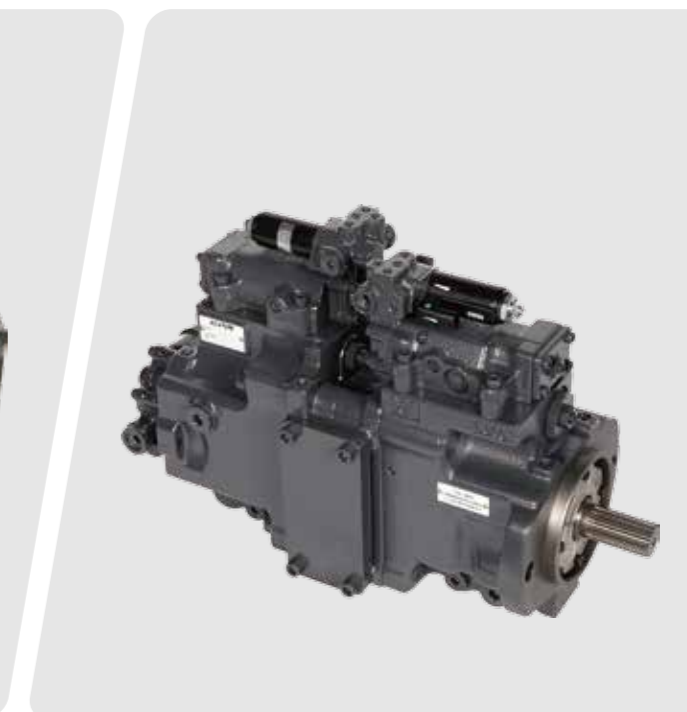

Hydraulic pump



Traveling motor

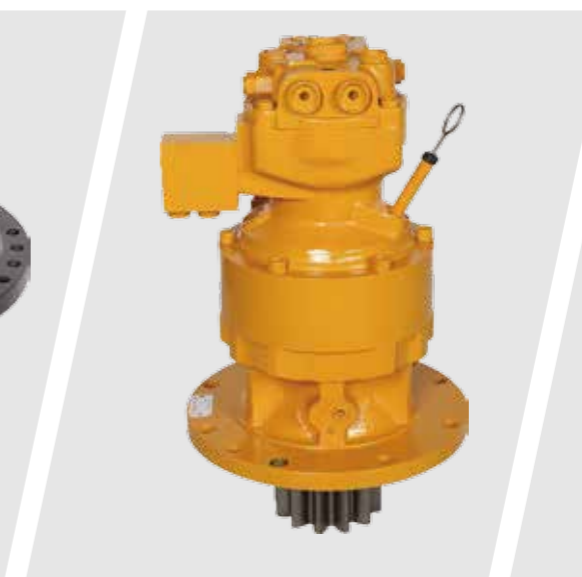

Slewing motor



Multi-way valve

○ Best core configuration

Power system

- It is fitted with air prefilter in standard configuration to filter foreign matters in air effectively, increase the service life of air filter and protect the engine.



Power system

- Fitted with 9" large-screen and high-accuracy air filter in standard configuration, to realize 2-stage filtering, with the filtering accuracy over 99.9%.
- Large capacity design, long service life and low maintenance cost
- Electronic alarm device, which is safe and effective

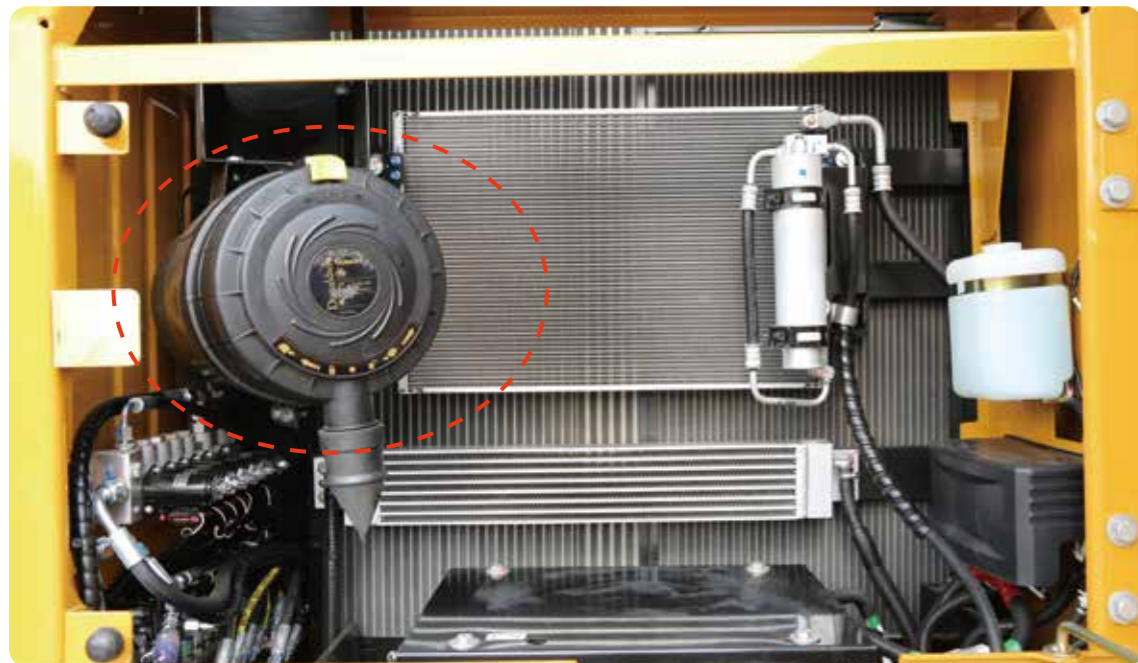

Power system

- Standard configuration: **ultra-large and high-accuracy primary fuel filter + secondary fuel filter**, to offer double protections and higher filtering efficiency. The service life is doubled based on the long-life design.
- Filter precision of coarse filter is 4μm, filter precision of fine filter is 5μm; they could filter out micro contaminants invisible to the naked eyes for ensuring safe use of the engine



○ Reinforced structure

Boom

- Rear support and center support of the boom adopt forgings for avoiding concentrated local welding stress and improving the durability
- Key positions are enveloped with fortified steel plate for severe working conditions.



The joint of rear support is supplemented with external stiffening plate to **have good adaption to the severe working conditions.**

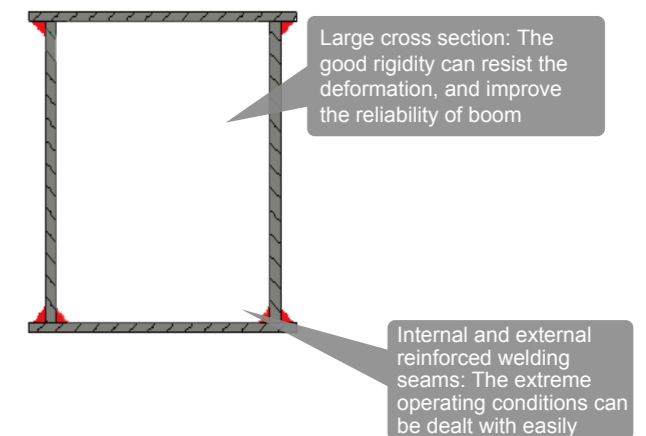

The rear support is fitted with forge type structure to avoid stress concentration of local weld and **improve the durability.**

Reinforced structure

Grab arm

- Front end of bucket rod is equipped with wear-resisting plate as reinforcing plate so that its service life is longer.
- Front end face of bucket rod is treated with new tungsten carbide process so that its wear resistance is double

Forged bearing: Replace the arc weld with straight butt weld, to avoid stress concentration of local weld.

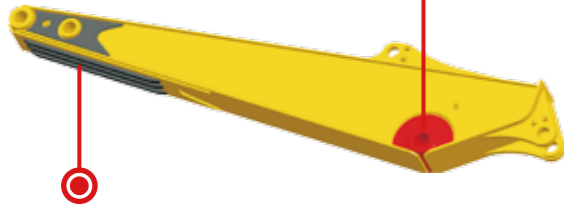

Wear-resistant rebar: The imported wear-resistant board is used, to avoid wear of bottom plate due to direct friction of sands during excavation and prolong the service life of bucket rod.



Bucket

- The bucket is fitted with imported wear-resistant plate as bottom plate, equipped with heavy-load rock bucket tooth, to improve the service life by over 50%.

With secondary arc shape of optimized design, the excavation resistance and the wear of sand and rock against the bucket body when excavating so that it saves energy and is more durable.

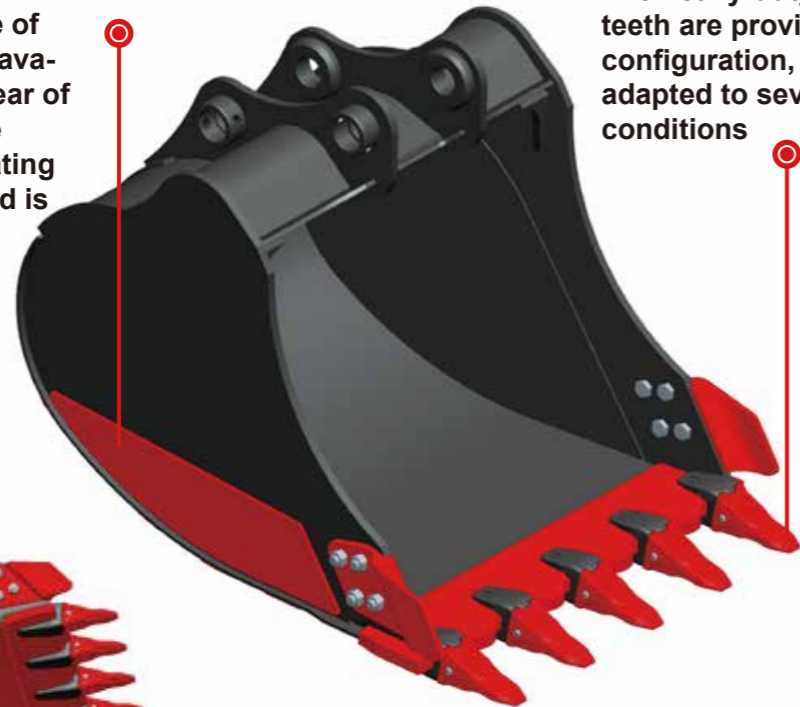

The heavy-duty rock bucket teeth are provided as standard configuration, so as to get adapted to severe operating conditions

The anti-wear steel plates specially manufactured for construction machinery are adopted, so that the service life of bucket is prolonged by more than 30%

Undercarriage

- The pioneering heavy-load and extended chassis, which is designed based on the conditions of mine, replaces the chain wheels with the supporting wheels and uses double chain wheels, to double the service life of the lower vehicle.
- The fixture of carrier wheel is reinforced on both sides so that the structure is more sturdy, durable and reliable.



Slewing platform

- Rotary platform: High-strength rotary platform, heightened D-shaped large-section side beam, increases the section height from 149 mm to 228 mm; it is firmer and supplemented with anti-collision triangle beam to resist higher impacts and increase the decorous feeling of the entire machine.

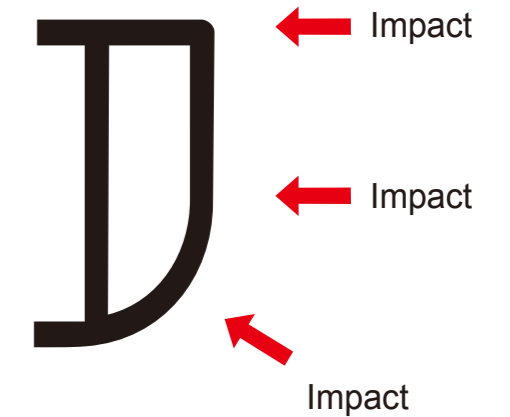

○ Improved R&D and test system

Test system

- Complete research, development and test system is the strong backup for excellent performance
- It has established complete machine endurance test center with full functions. Each model of excavator must be subjected to over 2,000h field excavating test.
- Important parts and components like working device, cab and hydraulic components etc. must be subject to fatigue test over 800,000 times.



○ Leading manufacturing technology

Manufacturing technology

- Leading manufacturing technology is a reliable guarantee for producing excellent products
- SANY has RGV assembling line and full-automatic welding robots, and possesses high-precision machining equipment and precise machining center.
- SANY's manufacturing and assembling lines won five-star national site in 2013 and national quality award in 2014.



REMARKABLE PERFORMANCE

More powerful

Engine

- Isuzu 4JJ1 engine that is exclusively supplied to SANY has strong power and reliable performance.

Isuzu Specific engine



Advantages of Isuzu engine:

- Wide application; the highest recognition by customer;
- Durable, fuel-efficient, cheap accessories, easy maintenance, the first choice of excavator!!!

More perfect operation

Electrically-controlled positive flow

- By using the electronically-controlled positive flow hydraulic system and three unique skills: Accurate flow distribution technique, advanced ACE control system and hydraulic system buffer technique, SANY has provided higher operation efficiency, higher controllability and better performance of the Machine. The excellent misoperation performance can offer you the perfect feeling of operation.

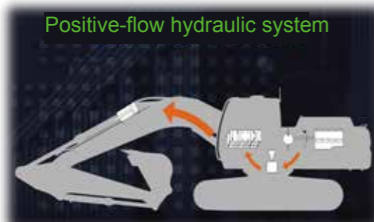

Accurate flow distribution technology

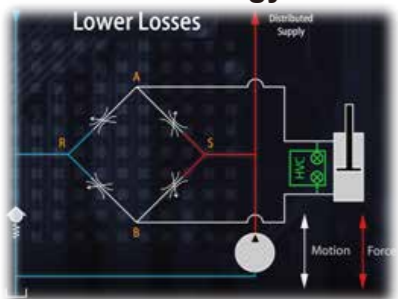

Reduced system pressure loss



Hydraulic system buffer technology

Lower energy consumption, higher efficiency

Fuel consumption and efficiency

- Compared with the rivals, the Machine's fuel consumption is 8% lower and efficiency is 9% higher.
- 20 more excavators can be loaded by a vehicle shift, and near 5000 more excavators can be loaded every year (rear-eight-wheel trailer)
- With higher fuel economy, SY155H can help you save almost RMB 10,000 in fuel consumption.



Higher excavation force

Force comparison

- Compared with the rivals of the same tonnage, the Machine's excavation force is 8.5% higher, to excavate the hard soil layer easily.
- Compared with the rivals of the same tonnage, the Machine's overall traction force is 7.3% higher, to realize powerful traction



Safety and environmental protection

Security configuration of international standard

Safety certification

- It conforms to the safety standards of multiple regions, such as **China, EU and North America**
- The cab on SY155H excavator is equipped with tip-over protection structure and falling object protection structure, and the safety certification for **TOPS** and **FOPS** has been obtained



Safety facility

- The area of left/right side window is increased by 5%, so that the visual field becomes wider
- Fire extinguisher and escape hammer
- Handrails for getting on the vehicle and large-area rearview mirror
- Seat belt, safety sign and cab protective net
- Protective cover for fan, and splash proof baffle



International cutting-edge environmental protection standards

Recoverable

- The metal cover panel which is recyclable and environmentally friendly is adopted; the materials which may cause pollution such as fiber reinforced plastics are not used



Environmental protection

- Environment engine is equipped and meets latest standard of National III
- Aluminum radiator and oil cooler are used
- Environmental paint is used to minimize environmental pollution
- Garden-type manufacturing site



Comfortable and convenient

○ Comfortable driving • As warm as family

Comfortable experience

- With high-grade trim parts, wide view, suspended seat, excellent vibration damping and noise reduction performance, the driving experience will be more comfortable
- The high-definition smart display screen, the fully-automatic air conditioner and properly-located air outlets lead to convenience and comfortability.
- Cigar lighter, ashtray, cup holder, file box and reading lamp all are complete



○ Easy maintenance

Convenient maintenance

- Large-area covering part is used. After it is opened, daily maintenance can be carried out on the ground; thus the maintenance is convenient and the accessibility is good
- Air filter, fuel oil coarse filter, fuel oil fine filter, engine oil filter and pilot filter element are within easy reach and can be maintained very conveniently



Convenient maintenance

- Filling of lubricating grease: The greasing filling ports on working device are arranged in a centralized manner, so that the lubricating grease can be remotely supplied to inaccessible locations, and thus it will be more convenient to carry out lubrication and maintenance
- Large new-type radiator: The protective net is mounted on outside of radiator, so that the dirt will be blocked on the outside of protective net, and it is only necessary to dismantle and clean up the protective net; the excellent radiating performance ensures that the engine will not get overheated after long-time operation
- The tilting type track rack: The tilting type track rack is adopted, so that the soil will drop off easily rather than be accumulated on track rack and the cleaning will become easier



Technical Specifications

Specification	
Overall weight	14100kg
Bucket capacity	0.22 ~ 0.7 (0.65) m ³

Engine	
Model	4JJ1-XKSC-05
Type	Four-stroke, water-cooled, dual-overhead camshaft, electronically-controlled high-pressure common-rail injection system, supercharged, intercooled
Rated power	84kW/2200rpm
Maximum torque	375Nm/1800rpm
Displacement	2.999L

Capacity of oil and coolant	
Fuel tank	240L
Hydraulic oil tank	150L
Engine oil	15L
Radiator	10L
Final drive	2×2.6L
Slewing drive	3L

Main performance	
Traveling speed (high/low)	5.5/3.5(km/h)
Slewing speed	12rpm
Gradeability	70% (35°)
Ground pressure	43kPa
Digging force of bucket	103kN
Excavating force of grab arm	67kN

Traveling part	
Number of track plates	45
Each carrier roller side	2
Each thrust wheel side	7
Standard track	500mm

Lifting Capacity

Boom---		4600mm		Grab arm---		2500mm		Tracks---		500mm		Counterweight---		2700kg		
Height of loading point (B) m		Radius of loading point (A)												Maximum distance		
		2.0m		3.0m		4.0m		5.0m		6.0m		7.0m		Loading capacity		Distance
		Longitudinal	Lateral	Longitudinal	Lateral	Longitudinal	Lateral	Longitudinal	Lateral	Longitudinal	Lateral	Longitudinal	Lateral	Longitudinal	Lateral	m
7m	kg					*3150	*3150							*2350	*2350	4.26
6m	kg							*3100	*3100					*2050	*2050	5.34
5m	kg							*3350	*3350	*2400	*2400			*1950	*1950	6.07
4m	kg					*3800	*3800	*3550	*3550	*3400	2850			*1900	*1900	6.56
3m	kg			*5650	*5650	*4500	*4500	*3900	3600	*3600	2800			*1900	*1900	6.88
2m	kg			*7250	7150	*5300	4750	*4350	3500	*3800	2750	*2250	2200	*1950	*1950	7.03
1m	kg			*6550	*6550	*5950	4550	*4750	3400	4000	2700	*2400	2150	*2050	*2050	7.03
Ground	kg			*6550	*6550	*6300	4450	*5000	3300	3950	2650			*2200	2200	6.89
-1m	kg	*4450	*4450	*8250	6650	*6350	4400	*5050	3250	3900	2600			*2500	2300	6.60
-2m	kg	*6750	*6750	*7950	6650	*6100	4400	*4850	3250	*3850	2600			*2950	2550	6.12
-3m	kg	*9350	*9350	*7000	6700	*5450	4400	*4200	3300					*3650	3000	5.41
-4m	kg			*5350	*5350	*4050	*4050							*3500	*3500	4.37

- The lifting capacity is calculated in accordance with ISO10560 and SAEJ1097, where limit coefficient of hydraulic system is 0.87 and tilting limit coefficient is 0.75;
- The item with the mark * is limited by hydraulic pressure and the item without the mark "*" is limited by stability;
- The lifting point is the front support hole of the grab arm (excluding the weight of the bucket). If additional accessories such as the bucket are added, they shall be deducted from the above lifting weight;

Machine Dimensions (mm)

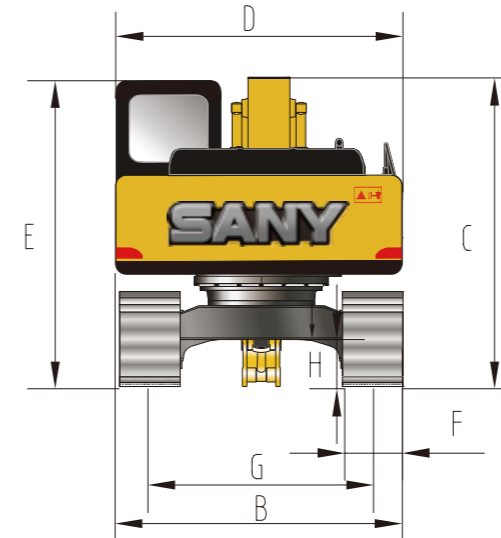

Overall dimensions	(Unit: mm)
A Overall length (in transportation state)	7870
B Overall width (in transportation state /in operation state)	2570
C Overall height (in transportation state)	2880
D Upper width	2490
E Total height to the cab top	2740
F Width of standard track plate	500
G Track gauge (in transportation state / in operation state)	1990
H Minimum ground clearance	425
I Slewing radius of tail	2210
J Grounding length of track	3010
K Track length	3730

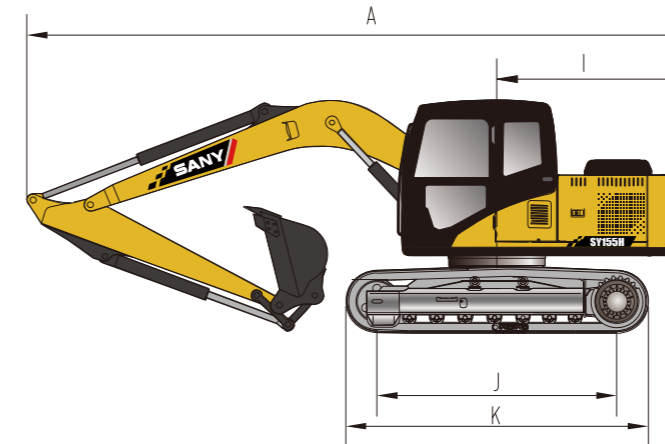

Performance parameters	
Total weight, kg	14100
Bucket capacity m ³	0.22 ~ 0.7 (0.65)
Rated power, kW/rpm	84/2200
Traveling speed (high/low), km/h	5.5/3.5
Slewing speed rpm	12
Gradeability	70%/35°
Ground pressure, kPa	43
Excavating force of bucket, kN	103
Excavating force of grab arm, kN	67

Operating Range (mm)

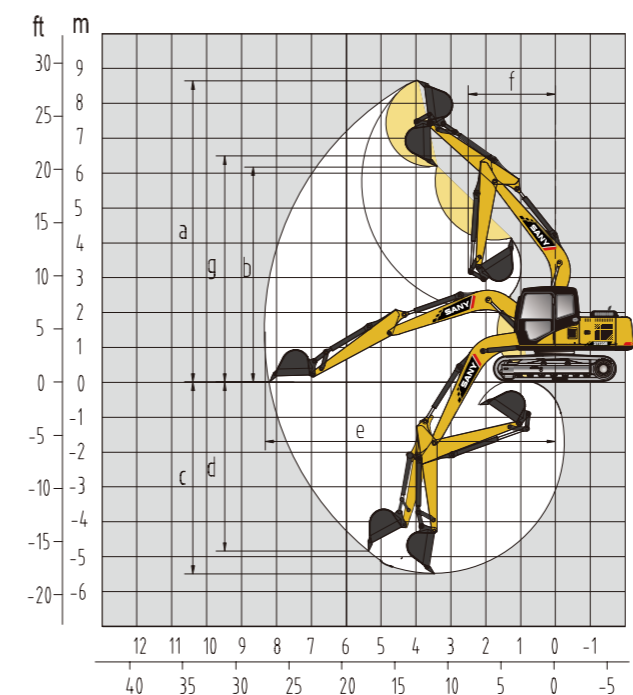

Operating range	(Unit: mm)
a Maximum excavating height	8685
b Maximum unloading height	6115
c Maximum excavating depth	5500
d Maximum excavating depth with vertical boom	5085
e Maximum excavating distance	8330
f Minimum slewing radius	2490
g Maximum height at minimum slewing radius	6495



Strong Power *SY155H* Model of heavy- load machines

SY155H hydraulic excavator



Thunder power,
heavy load model

19/20